

# Dillon Casefeed

## Instruction Manual

January 2018

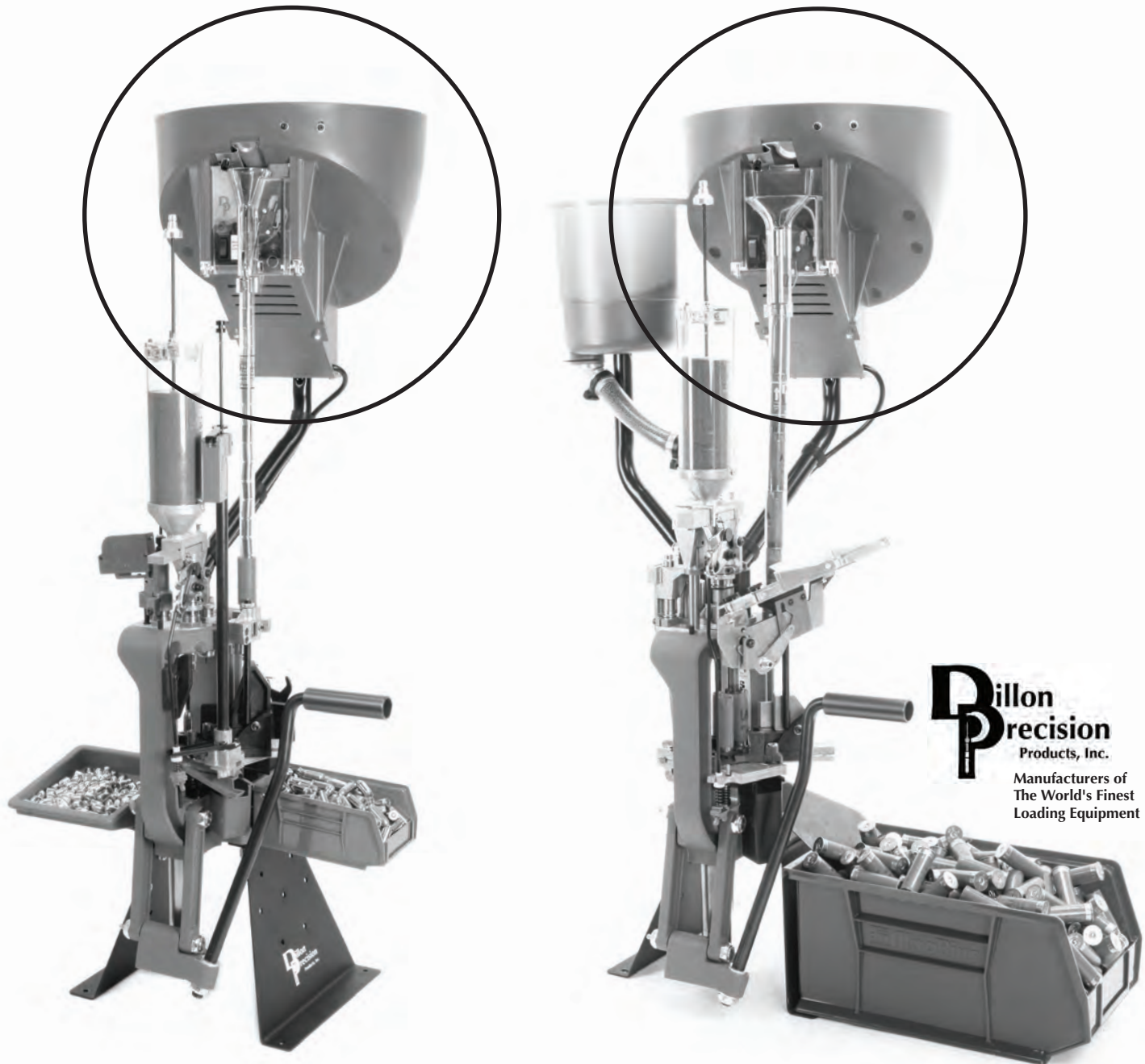

**XL 650 and SL 900 Casefeed Instruction Manual**

# Casefeed Bowl Assembly, Version 2

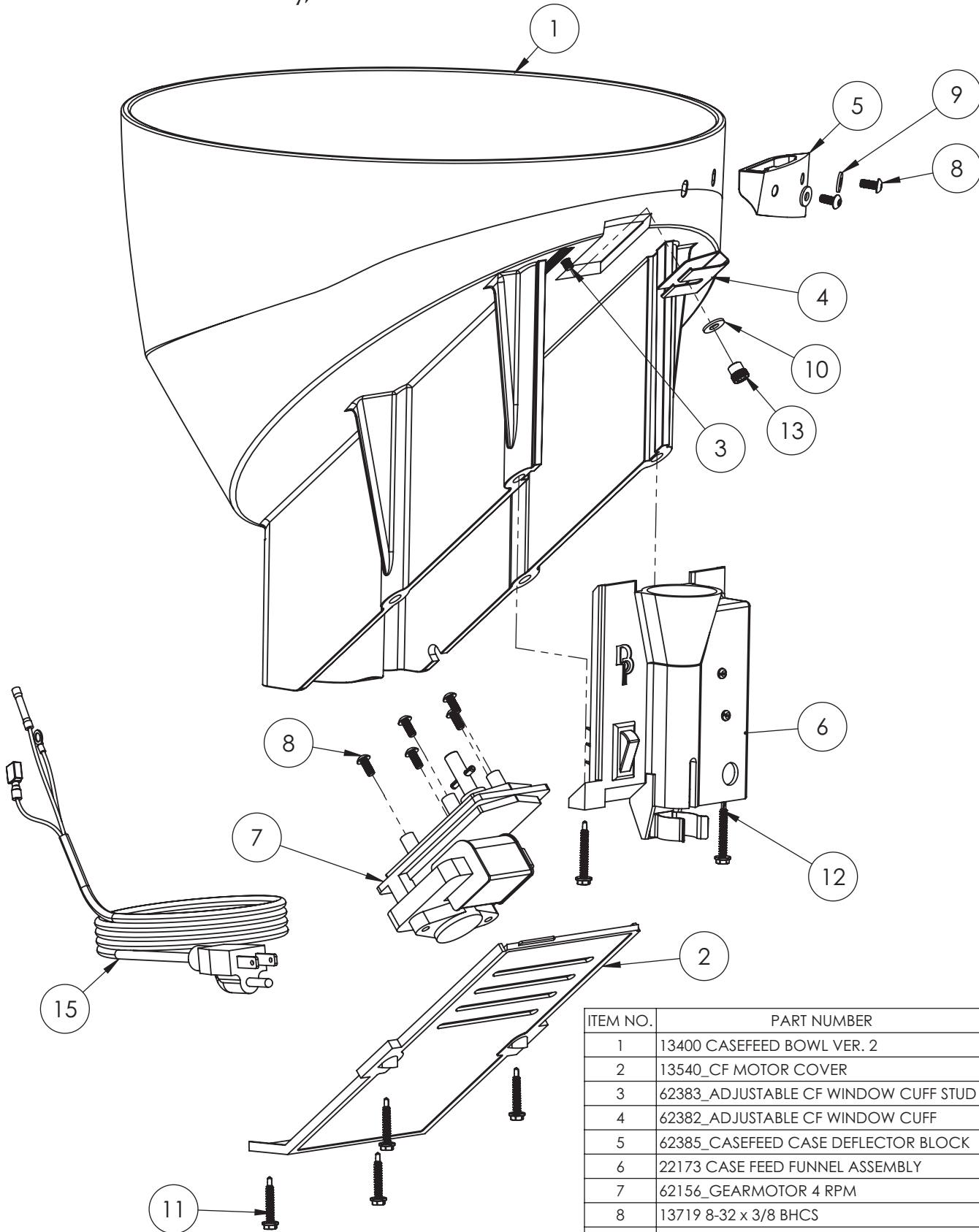

ITEM NO.	PART NUMBER	QTY.
1	13400 CASEFEED BOWL VER. 2	1
2	13540_CF MOTOR COVER	1
3	62383_ADJUSTABLE CF WINDOW CUFF STUD	1
4	62382_ADJUSTABLE CF WINDOW CUFF	1
5	62385_CASEFEED CASE DEFLECTOR BLOCK	1
6	22173 CASE FEED FUNNEL ASSEMBLY	1
7	62156_GEARMOTOR 4 RPM	1
8	13719 8-32 x 3/8 BHCS	7
9	17472 WASHER #8 .032 THICKNESS	2
10	13738 SD-B #10 ROD WASHER	1
11	14137 #8 x 1 COVER SCREW ZINC	4
12	17586 #8 x 1.25 FUNNEL SCREW	2
13	62384_ADJUSTABLE CF WINDOW CUFF NUT	1
15	13539_CASEFEED CORD SET	1

## Casefeed Funnel Assembly, Part # 22173

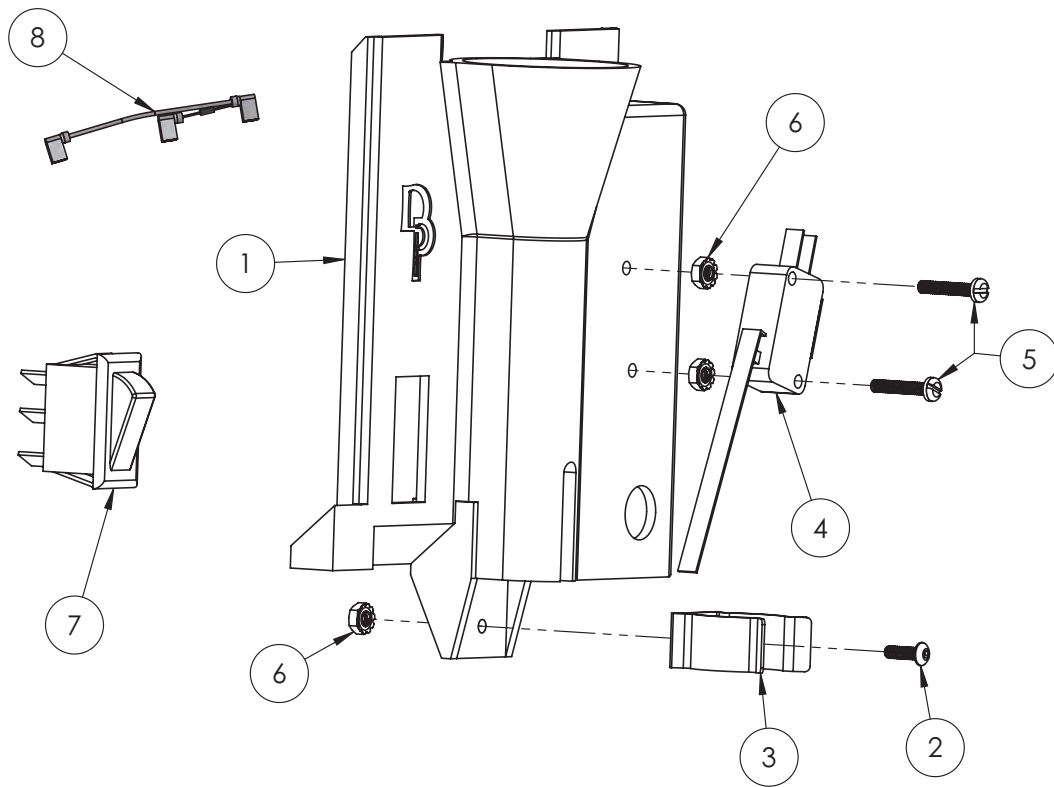

ITEM NO.	PART NUMBER	QTY.
1	11423 NEW CASE FEED FUNNEL SMALL THRU HOLE	1
2	18918 550CF 4-40 x 3/8 BHCS	1
3	13859 CF TUBE CLIP	1
4	13779_MICRO SWITCH	1
5	13954 4-40 x 5/8 PAN HEAD SCREW	2
6	14038 4-40 KEPSNUT	3
7	13812_3 WAY SWITCH	1
8	13339_DIODE WIRE	1

## Casefeed Plates

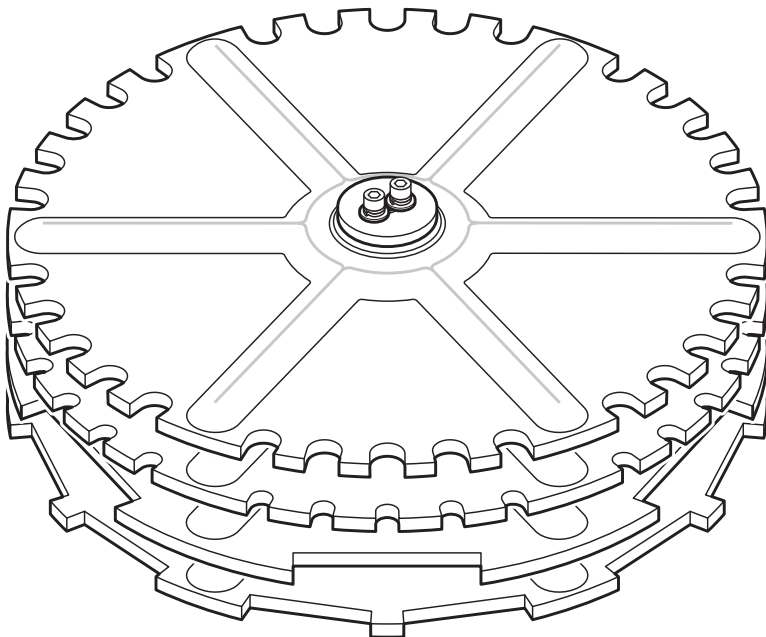

- 1 21072 Large Pistol CF Plate
- 2 21073 Small Pistol CF Plate
- 3 21075 Large Rifle CF Plate
- 4 21074 Small Rifle CF Plate  
(Magnum Rifle Casefeed Plate Not Shown)

## XL 650 Casefeed Section



### Installation of the Optional Casefeeder

1. Remove the casefeed parts bag from the casefeed bowl and remove the casefeed assembly from the box FIG 1.



a. Spacer Washer FIG 2.

Some calibers call for a spacer washer to be used under the casefeed plate. Installation of this washer raises the plate up a bit to make the feeder function properly with longer pistol cases (see chart on Page 8 of this manual for more detailed information).



Note: The spacer washer does not come factory installed.

To Install the Spacer Washer:

a.1. FIG 3 Remove the casefeed plate.

a.2. With the casefeed plate removed, disassemble the clutch drive. To do so unscrew the two clutch screws.

a.3. Install the spacer washer between the lower clutch and the casefeed plate.

a.4. Reassemble the clutch drive and reinstall the casefeed plate. (Note how the clutch drive engages the drive pin).

b. Clutch Adjustment FIG 4:

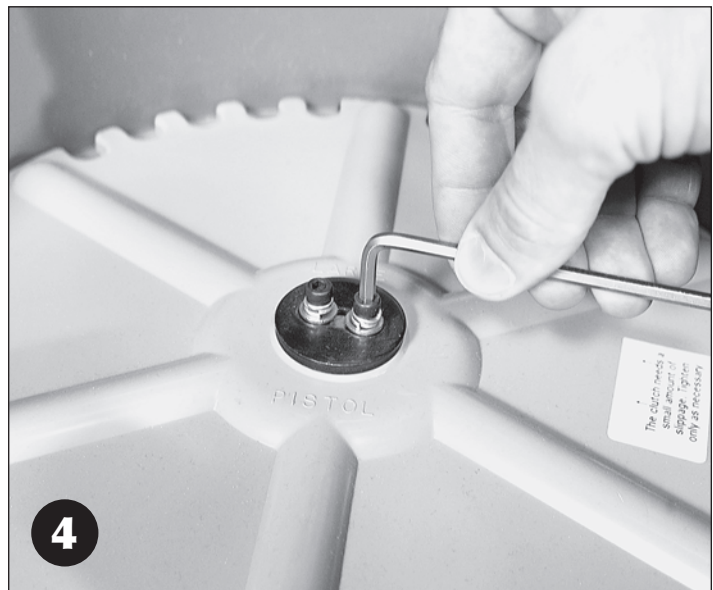

Note: The clutch comes factory adjusted (if you don't have to install the spacer washer you shouldn't have to adjust the clutch drive).

The two socket-head machine screws (#13732) should be just tight enough for the clutch to drive the casefeed plate under a normal load of brass. To check this, place the casefeed assembly in front of you on the bench. With the switch off, plug the casefeeder in. Turn the switch to the down (low) position and observe the movement of the plate. You should be able to cause the clutch to slip, using moderate finger pressure, without stalling the motor. Alternately tighten and loosen the two machine screws evenly, observing the effect on the holding power of the clutch. The correct setting will stall the plate before stalling the motor, yet not slip when the casefeed bowl is about half full of brass.

Note: The casefeed bowl is not designed to be completely filled with brass. If it is fully loaded it will not function reliably. The rated capacity of the casefeeder is about 1/2 of the bowl's physical capacity.

Before placing the casefeed bowl on the casefeed post, take a moment to look over and understand the casefeed assembly and how it works. If you like, you can run the casefeeder before placing it on top of the casefeed post. To do so, plug in the casefeeder and fill it with about 50 cases. Hold the casefeeder FIG 5 so the funnel is vertical. Place the cartridge bin under the funnel and turn it on. Experiment using both the high and low settings.

Dillon casefeeders are low-RPM units, operating between 2 and 4 RPMs (approximately).



2. Remove the set screw from the accessory bag and thread it into the casefeed assembly FIG 6.



3. Place the casefeed bowl onto the casefeed post FIG 7.



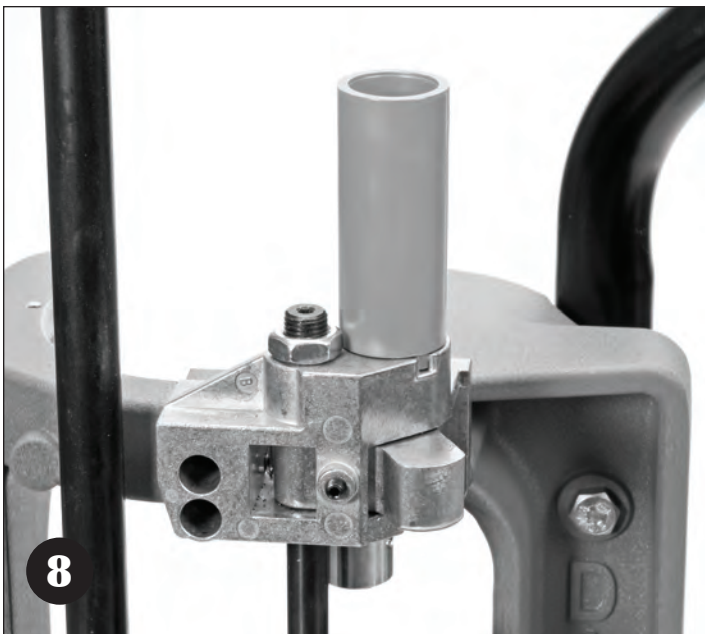

4. Place the casefeed adapter on the casefeed body FIG 8. Note how the key fits into the notch on the casefeed body.

Note: Casefeed adapters are caliber specific. Crosscheck your casefeed adapter with the one listed in the caliber conversion chart in your XL 650 manual (for the caliber you're loading) to ensure that you have the correct one installed in your machine.



5. Align the casefeed bowl so the spring clamp is directly over the casefeed adapter. Place the casefeed tube into the casefeed adapter then snap the tube into the clamp FIG 9.

Note: One end of the casefeed tube is beveled and one end is squared off. Insert the squared end of the tube (down) into the top of the casefeed adapter.



6. Using A 5/32" Allen wrench, snug (5 to 7 inch pounds) the machine screw against the casefeed mounting post FIG 10 to prevent the casefeed bowl from rotating.

**How to set the adjustable Casefeed Window Cuff and Case Deflector Block on the Casefeed unit.**

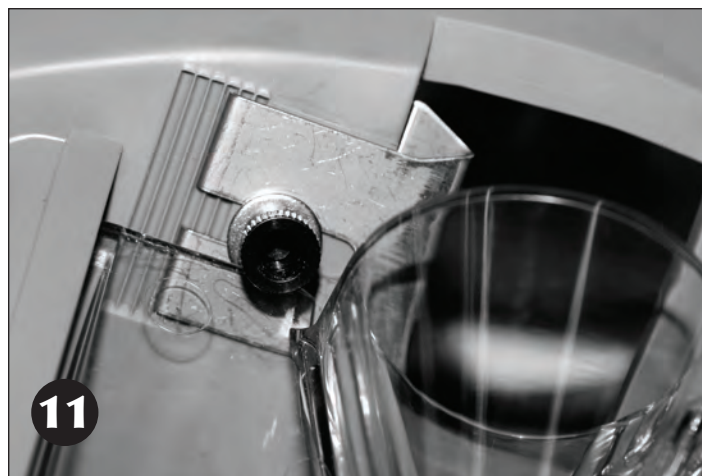

**Casefeed Window Cuff**

The Casefeed Window Cuff (FIG 11) is now adjustable. This will allow for faster and more reliable case feeding of longer (i.e. 338 Lapua, 300 Win Mag) and shorter rifle cases (i.e. 300AAC Blackout, 7.62x39). The window now has six positions that the Cuff can be adjusted to. Starting from the left, the third position from the left will give you the standard opening width of the previous unit. This adjustment will work for all pistol and most all of your standard rifle cartridges. With the Window Cuff adjusted to the full left position it will allow for faster case feeding of larger rifle calibers (i.e. 338 Lapua, 300 Win Mag). With the

window adjusted to the full right position it will allow for case feeding of shorter bottleneck rifle cases (i.e. 300AAC Blackout, 7.62x39) utilizing standard rifle Casefeed Plates. The Cuff can be adjusted by loosening the black knurled nut, it incorporates a 3/16" hex. Slide the Cuff into position, making sure that the small leg is locked into the adjustment notch for the desired opening size, and retighten the nut to no more than 10 to 12 inch-pounds to lock it into position.



### Case Deflector Block

The Casefeed Bowl utilizes an adjustable Case Deflector Block FIG 12. The deflector has two positions for operation, fully lowered (FIG 13) for pistol and fully raised for rifle and shotgun cartridges (see FIG 19 on Page 11). The Block can be adjusted by loosening the two #8 screws with a 3/32" hex wrench. Slide the block to the desired position based on pistol or rifle cartridge and tighten the two screws to no more than 5 to 7 inch-pounds to lock the Case Deflector Block into position.



## Troubleshooting

### Casefeeding

- A. Casefeeder is on but will not rotate.
    1. Brass caught under casefeed plate.
    2. Casefeed is too full.
    3. Bad micro-switch.
  - B. Cases are falling down tube upside down jamming in the top tube, etc.
    1. Using the wrong casefeed plate for that caliber.
    2. Casefeeder is too full.
    3. The machine is not secured to a sturdy enough bench.
  - C. Casefeed tube (13761 or 14392) appears too short.
    1. Casefeed is not pushed down all the way on the casefeed mounting post (13831).
  - D. Cases hanging up at micro-switch or micro-switch inoperative.
    1. Check the angle of the switch lever and adjust as necessary.
      - a. Too sharp an angle will cause cases to hang up.
      - b. Too shallow an angle will cause incomplete shutoff.
  - E. Cases jamming at the casefeed arm (13716).
    1. Wrong size or loose body bushing for caliber being loaded.
    2. Operating machine too fast.
    3. Short stroking the machine.
    4. Dented or squashed cases.
- NOTE: If the power cord ever needs replacing, use only a qualified electrician to install the new power cord or return it to the factory.

# XL 650 Casefeed Adjustment Specifications and Casefeed Plate Chart

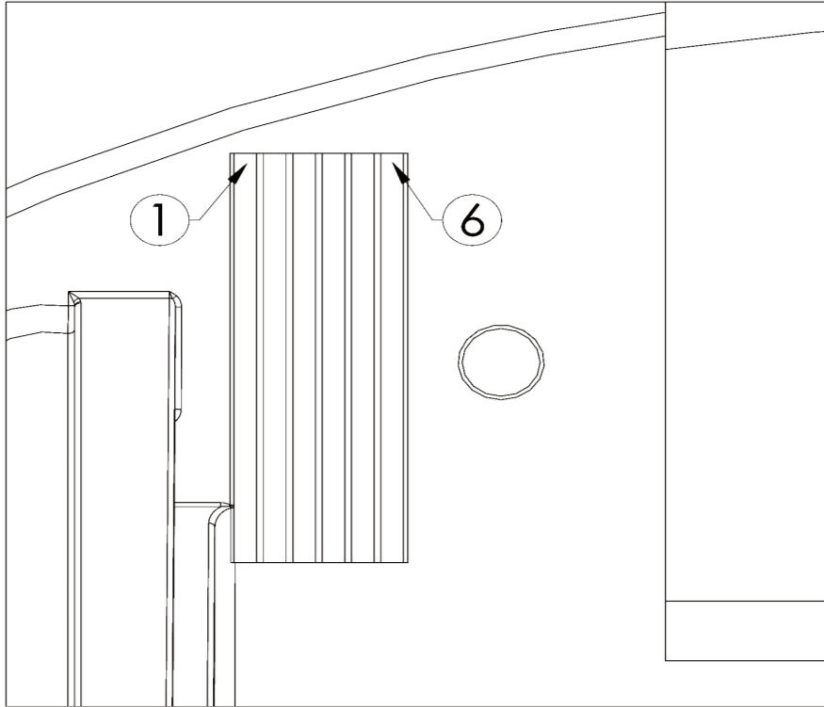

The chart below outlines the recommended casefeed plate and starting positions for the window opening position and case deflector position. Adjustment to the window position and case deflector may be necessary dependent upon the variation of your setup.

CALIBER	CASEFEED PLATE	WINDOW POSITION	DEFLECTOR POSITION	MOTOR SPEED	CALIBER	CASEFEED PLATE	WINDOW POSITION	DEFLECTOR POSITION	MOTOR SPEED	CALIBER	CASEFEED PLATE	WINDOW POSITION	DEFLECTOR POSITION	MOTOR SPEED
.30 Luger, .30 Mauser	SMALL PISTOL	#3	DOWN	HIGH	.22 Remington Jet	SMALL RIFLE	#3	DOWN	HIGH	7.62x54	LARGE RIFLE	#1	UP	LOW
.32 ACP, 7.65MM	SMALL PISTOL	#3	DOWN	HIGH	.218 Bee	SMALL RIFLE	#3	DOWN	HIGH	.30 AR	LARGE RIFLE	#6	DOWN	HIGH
.32 Short Colt	SMALL PISTOL	#3	DOWN	HIGH	.220 Swift	SMALL RIFLE	#3	DOWN	HIGH	.30M1 Carbine	SMALL RIFLE	#6	DOWN	HIGH
.32 S&W	SMALL PISTOL	#3	DOWN	HIGH	.222 Remington Magnum	SMALL RIFLE	#3	DOWN	HIGH	.300 Blackout	SMALL RIFLE	#6	DOWN	HIGH
.32 H&R Magnum	SMALL PISTOL	#3	DOWN	HIGH	.22-250	SMALL RIFLE	#3	DOWN	HIGH	.300 Wby./Win. Mag.	MAGNUM RIFLE	#1	UP	LOW
.327 Federal Magnum	SMALL PISTOL	#3	DOWN	HIGH	.25-20 Winchester	SMALL RIFLE	#3	DOWN	HIGH	.300 WSM/RSAUM	MAGNUM RIFLE	#1	UP	LOW
7mm TCU	SMALL PISTOL	#3	DOWN	HIGH	.223 Win./5.56x45mm	SMALL RIFLE	#3	DOWN	HIGH	.300 Rem. Ultra Mag.	MAGNUM RIFLE	#1	UP	LOW
9mm, 9x21, .38 Super	SMALL PISTOL	#3	DOWN	HIGH	.223 WSSM	SMALL RIFLE	#3	DOWN	HIGH	.300H&H/.308 Norma Mag.	MAGNUM RIFLE	#1	UP	LOW
9x18 Makarov	SMALL PISTOL	#3	DOWN	HIGH	.224 Wby. Mag.	SMALL RIFLE	#3	DOWN	HIGH	.32-20 Winchester	SMALL PISTOL	#3	DOWN	HIGH
9x25 Dillon	SMALL PISTOL	#3	DOWN	HIGH	.243 Win., 6mm Rem.	SMALL RIFLE	#3	DOWN	HIGH	.303 British	LARGE RIFLE	#1	UP	LOW
.380 ACP	SMALL PISTOL	#3	DOWN	HIGH	.243 WSSM	SMALL RIFLE	#3	DOWN	HIGH	.30-30 Winchester	LARGE RIFLE	#1	UP	LOW
.38 Super Comp	SMALL PISTOL	#3	DOWN	HIGH	.25-06, .257 Roberts	SMALL RIFLE	#3	DOWN	HIGH	.308 Marlin Express	LARGE RIFLE	#1	UP	LOW
.38 Special,	LARGE PISTOL	#3	DOWN	HIGH	.25 WSSM	SMALL RIFLE	#3	DOWN	HIGH	.308 Win.	LARGE RIFLE	#1	UP	LOW
.357 Magnum	LARGE PISTOL*	#3	DOWN	HIGH	.256 Win. Mag.	SMALL RIFLE	#3	DOWN	HIGH	.30-06	LARGE RIFLE	#1	UP	LOW
.357 SIG	LARGE PISTOL	#3	DOWN	HIGH	.257 Ack. Imp.	SMALL RIFLE	#3	DOWN	HIGH	.30 T/C	LARGE RIFLE	#1	UP	LOW
10mm	LARGE PISTOL	#3	DOWN	HIGH	.257 Wby. Mag.	SMALL RIFLE	#3	DOWN	HIGH	.325 WSM	LARGE RIFLE	#1	UP	LOW
.40 S&W	LARGE PISTOL	#3	DOWN	HIGH	6.5 Creedmoor	LARGE RIFLE	#3	DOWN	HIGH	.338 Win., .340 Wby.	MAGNUM RIFLE	#1	UP	LOW
.41 Mag.	LARGE PISTOL	#3	DOWN	HIGH	6.5 Grendel	SMALL RIFLE	#6	DOWN	HIGH	.338 Rem. Ultra Mag.	MAGNUM RIFLE	#1	UP	LOW
.44 Special, .44 Magnum	LARGE PISTOL	#3	DOWN	HIGH	6.5 Rem. Mag.	SMALL RIFLE	#3	DOWN	HIGH	.350 Rem. Mag.	MAGNUM RIFLE	#1	UP	LOW
.45 ACP	LARGE PISTOL	#3	DOWN	HIGH	6.5x55	SMALL RIFLE	#3	DOWN	HIGH	8x57 Mauser	MAGNUM RIFLE	#1	UP	LOW
.45 GAP	LARGE PISTOL	#3	DOWN	HIGH	.264 Win. Mag.	SMALL RIFLE	#3	DOWN	HIGH	.375 H&H Mag.	MAGNUM RIFLE	#1	UP	LOW
.45 Auto Rim	LARGE PISTOL	#3	DOWN	HIGH	6.8mm SPC	SMALL RIFLE	#6	DOWN	HIGH	.375 Rem. Ultra Mag.	MAGNUM RIFLE	#1	UP	LOW
.45 Colt/S&W, .454 Casull	LARGE PISTOL	#3	DOWN	HIGH	7mm TCU	SMALL RIFLE	#3	DOWN	HIGH	.38-40 Win.	LARGE PISTOL	#3	DOWN	HIGH
.45 Win. Mag.	LARGE PISTOL	#3	DOWN	HIGH	.270 Winchester	LARGE RIFLE	#1	UP	LOW	.444 Marlin	LARGE RIFLE	#1	DOWN	HIGH
.460 S&W	LARGE PISTOL	#3	DOWN	HIGH	.270 Wby. Mag.	LARGE RIFLE	#1	UP	LOW	.44-40 Win.	LARGE PISTOL	#3	DOWN	HIGH
.475 Linebaugh, .480 Ruger	LARGE PISTOL	#3	DOWN	HIGH	7mm DAKO	LARGE RIFLE	#1	UP	LOW	.458 Bushmaster	LARGE RIFLE	#6	DOWN	HIGH
.500 S&W Magnum	LARGE RIFLE	#6	DOWN	HIGH	7mm Rem./Wby. Mag.	LARGE RIFLE	#1	UP	LOW	.458 SOCOM	LARGE RIFLE	#6	DOWN	HIGH
.50 AE	LARGE PISTOL	#3	DOWN	HIGH	7mm. Ult. Mag.	LARGE RIFLE	#1	UP	LOW	.458 Win. Mag.	MAGNUM RIFLE	#1	UP	HIGH
.17 Remington	SMALL RIFLE	#3	DOWN	HIGH	7mm Rem. SAUM	LARGE RIFLE	#1	UP	LOW	.45-70 Government	LARGE RIFLE	#1	DOWN	HIGH
.204 Ruger	SMALL RIFLE	#3	DOWN	HIGH	7MM STW	LARGE RIFLE	#1	UP	LOW					
.221 Remington Fireball	SMALL RIFLE	#3	DOWN	HIGH	7mm WSM, .270 WSM	LARGE RIFLE	#1	UP	LOW					
.22 Hornet	SMALL RIFLE	#3	DOWN	HIGH	7.62x39	LARGE RIFLE	#6	DOWN	HIGH					

ITEMS WITH "\*" REQUIRE THE SPACER WASHER (PART# 13703) BETWEEN THE CLUTCH AND PLATE



## SL 900 Casefeed Bowl Assembly, Version 2

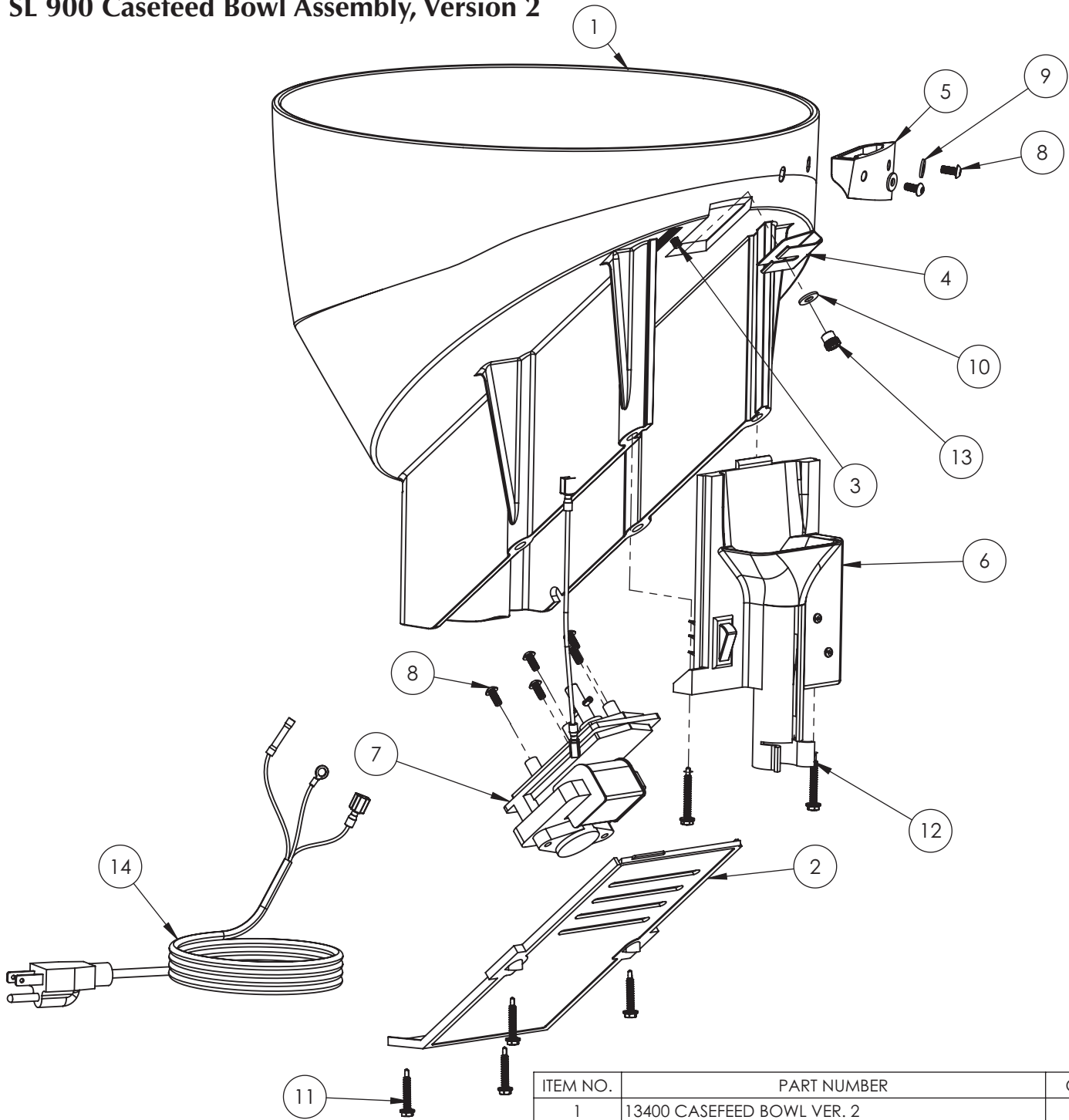

ITEM NO.	PART NUMBER	QTY.
1	13400_CASEFEED BOWL VER. 2	1
2	13540_CF MOTOR COVER	1
3	62383_ADJUSTABLE CF WINDOW CUFF STUD	1
4	62382_ADJUSTABLE CF WINDOW CUFF	1
5	62385_CASEFEED CASE DEFLECTOR BLOCK	1
6	97108_CASE FEED FUNNEL ASSEMBLY	1
7	62400_SL900 3RPM MOTOR W/PIN	1
8	13719 8-32 x 3/8 BHCS	7
9	17472 WASHER #8 .032 THICKNESS	2
10	13738 SD-B #10 ROD WASHER	1
11	14137 #8 x 1 COVER SCREW ZINC	4
12	17586 #8 x 1.25 FUNNEL SCREW	2
13	62384_ADJUSTABLE CF WINDOW CUFF NUT	1
14	13539_CASEFEED CORD SET	1

## SL 900 Casefeed Section

While the casefeed unit is on the bench, familiarize yourself with the operation of the casefeeder. Place a handful of empty hulls into the casefeed bowl (approx. 10). Hold the bowl in the upright position and turn the unit on. Watch the disc rotate. As the disc turns, the hulls fall into the open pockets around the disc and as they travel around, the hulls exit thru the window into the clear funnel and then down past the microswitch. Later, when the casefeed is mounted, you will see the microswitch shut the motor off when a hull is next to the microswitch.

Before installing the SL 900 casefeeder, remember to install the set screw first (#13685). Position the casefeeder above the casefeed post (#17123) to the right side of the machine. Place the casefeed unit on the post staying clear and away from the shot post (#17124). Next, insert the bottom of the casefeed tube (#16705) into the casefeed sleeve (#17130). Now snap the top of the casefeed tube into the clear funnel (#16704). Visually align the casefeed tube, then snug the set screw (#13685) on the rear of the casefeed unit.

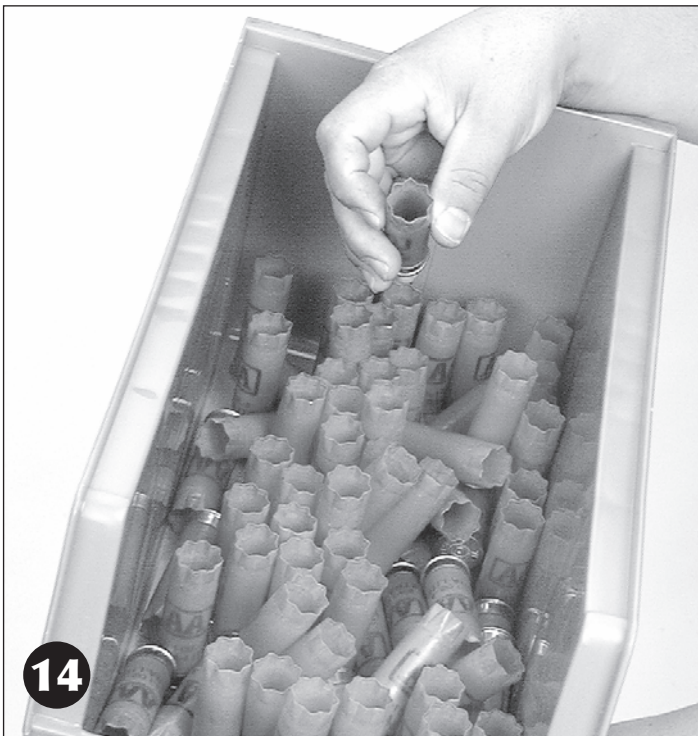

1. Using a Dillon bin (#17125) or box, gather up to 80 empty, fired hulls. FIG 14

Always examine the hulls for rocks, dirt, mud or other cases that may get stuck inside. Also look for hulls that may appear stepped on or flattened. Go ahead and squeeze them round again so they won't get stuck in the casefeed tube (#16705). FIG 15

Pour the hulls into the casefeeder and turn the unit on. The casefeeder will run until the casefeed tube (#16705) has filled, then shuts off automatically when a



hull trips the microswitch FIG 16. Insure that the casefeed tube is fully seated into its clamp.

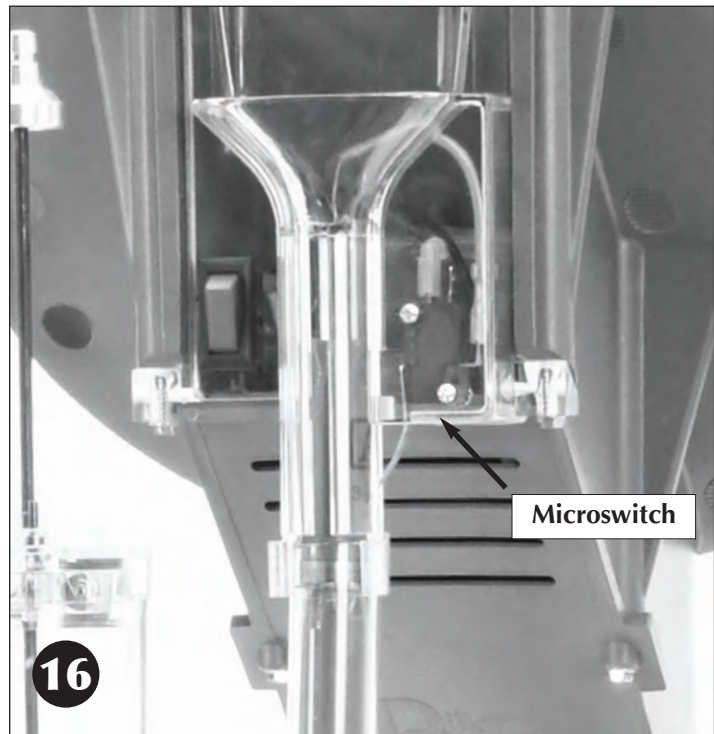

**How to set the adjustable Casefeed Window Cuff and Case Deflector Block on the Casefeed unit.**

### Casefeed Window Cuff

The Casefeed Window Cuff (FIG 17) is now adjustable. This will allow for faster and more reliable case feeding of shotgun hulls. The window now has six positions that the Cuff can be adjusted to. Starting from the left, the third position from the left will give you the standard opening width of the previous unit. With the Casefeed Window adjusted to the full left position it will allow for faster case feeding of the shotgun hulls. This position will work for all 12 gauge, 20 gauge and



28 gauge hulls. The Cuff can be adjusted by loosening the black knurled nut – it incorporates a 3/16" hex. Slide the Cuff into position, making sure that the small leg is locked into the adjustment notch for the desired opening size, and retighten the nut to no more than 10-12 in.-lbs. to lock it into position.



### Case Deflector Block

The Casefeed Bowl utilizes an adjustable Case Deflector Block FIG 18. For the SL 900, the Case Deflector Block needs to be in the highest position of adjustment FIG 19. If you need to make an adjustment to the positioning for your personal application, use the



following adjustment procedure: The Block can be adjusted by loosening the two #8 screws with a 3/32" hex wrench, adjusting it to the desired position, and tighten the two screws to no more than 5 to 7 inch-pounds to lock the Case Deflector Block into position.

### Troubleshooting

#### Casefeeder

1. General casefeeder information: Capacity is 80 shotshells. Electric motor information: 110V AC for US customers and 220V AC (3 RPM) for European customers.

2. The shotshells jam in the clear funnel. Always check the shotshells to make sure that no flattened or stepped on shotshells get into the casefeeder.

Suggestion: Use the clear feed tube to gage any shotshell to make sure that it can slide through the tube before placing it in the casefeeder bowl.

3. It looks like half of a shotshell is hanging out of the bottom of the casefeed body. A shotshell can jam in the casefeed body if the mouth of the shotshell is so deformed that it gets stuck on the casefeed phish inside the casefeed body. Simply remove the shotshell by pulling it out.

4. I have noticed that the microswitch does not shut the motor off. The microswitch uses the pressure of the shotshell against the aluminum arm on the switch to turn the motor off. You can bend the aluminum arm as needed to assure that the switch is activated.

5. All of a sudden the hulls stopped feeding into the casefeed tube. The motor is on, but the disc isn't rotating, why not? It is possible for an undersized or deformed hull to get wedged under the disc. As the hull went past the exit window, it continued around then was forced under the disc. Empty the bowl of all the hulls. Grip the disc firmly and remove it from the casefeed bowl. Clean out the bowl. Reinstall the disc, place approximately 20 empty hulls into the casefeeder and test-run the unit.

NOTE: If the power cord ever needs replacing, use only a qualified electrician to install the new power cord or return it to the factory.

Maintenance Tip: When switching from one disc to another, make sure that there are no rocks or debris in the bottom of the bowl before replacing the disc. This can cause interrupted rotation of the disc.

### **Electric Motor Information**

Dillon casefeeders are low-RPM units, operating between 2 and 4 RPMs (approximately).

110VAC 60Hz .3amp for US customers

220VAC 50Hz .13amp (3 RPM) for European customers

### **XL 650 Casefeed Information**

Large Pistol	<b>110v</b> 21080	<b>Euro. 220v</b> 97025
Large Rifle	<b>110v</b> 21081	<b>Euro. 220v</b> 97022
Small Pistol	<b>110v</b> 21079	<b>Euro. 220v</b> 97021
Small Rifle	<b>110v</b> 21082	<b>Euro. 220v</b> 97023

### **SL 900 Casefeed Information**

12 gauge	<b>110v</b> 97037	<b>Euro. 220v</b> 97118
20/28 gauge	<b>110v</b> 97036	<b>Euro. 220v</b> 97125

## **Dillon Precision Products, Inc.**

8009 E. Dillon's Way • Scottsdale, AZ 85260 USA

Tel. +1-480-948-8009

Fax +1-480-998-2786

[www.dillonprecision.com](http://www.dillonprecision.com)